

## Investigation of the role of internet marketing, word of mouth communication and brand awareness on purchasing decisions: An empirical study in online stores

Tita Hariyanti<sup>a\*</sup>, Mulyono<sup>b</sup>, Eti Setiawati<sup>c</sup>, Gustiarti Leila<sup>d</sup>, Hadi Purnomo<sup>e</sup>, Nicko Albart<sup>f</sup>, Yogi Makbul<sup>g</sup> and Indarti Indarti<sup>b</sup>

<sup>a</sup>Department of Public Health, Universitas Brawijaya, Malang, Indonesia

<sup>b</sup>Universitas Negeri Surabaya, Indonesia

<sup>c</sup>Universitas Brawijaya, Malang, Indonesia

<sup>d</sup>Psychology Faculty of Universitas Sumatera Utara, Indonesia

<sup>e</sup>Universitas Mitra Bangsa, Indonesia

<sup>f</sup>Universitas Paramadina, Indonesia

<sup>g</sup>Institut Teknologi Bandung, Indonesia

### CHRONICLE

#### Article history:

Received: January 6, 2024

Received in revised format: February 20, 2024

Accepted: April 19, 2024

Available online: April 19, 2024

#### Keywords:

Internet Marketing

Word of Mouth Communication

Brand Awareness

Purchasing Decisions

Online Stores

### ABSTRACT

This research aims to investigate the role of internet marketing, word-of-mouth and brand awareness on purchasing decisions in online stores. The respondent sampling technique used in this research is a non-probability sampling technique, which uses a purposive sampling technique. The responses to this research were from 468 online store consumers. Measurements of “Internet Marketing”, “Word of Mouth Communication”, “Brand Awareness” and “Purchasing Decisions” were carried out using a seven-point Likert scale, ranging from strongly agree (1) to strongly disagree (7). In this research, the data was analyzed using the Partial Least Square (PLS) method with SmartPLS version 3.0 software. The stages of research data analysis are outer model testing, namely unified validity and reliability, inner model testing and hypothesis testing. Based on the results of data analysis, it is concluded that internet marketing, word-of-mouth and brand awareness had positive and significant effects on purchasing decisions. Better internet marketing will improve consumer purchasing decisions, brand awareness plays an important role in consumer purchasing decisions, and consumers will carry out word-of-mouth activities and tell other people about consumer experiences after consuming products, electronic word of mouth can help consumers in making buying decisions. Based on the results of data analysis, the study provides managerial implications as follows: online stores should evaluate the Internet marketing strategy used by the company by looking for information about what is currently trending among the public and forming a special team to carry out Internet marketing strategies to make them more attractive and creative and provide more complete information regarding products are marketed so that they attract consumers to make purchasing decisions.

## 1. Introduction

Developments in the business world are getting faster and competition is getting tighter, and this requires every business actor to be able to exploit all the potential and opportunities they must overcome the weaknesses and threats they face, creating a competitive advantage, and to establish and improve relationships with customers (Aileen et al., 2921). Developments in the increasingly global business world and very fast-moving economic developments will have an impact on the strategies implemented by companies (Haudi et al., 2022). As business develops today, challenges and competition are getting sharper in capturing market share. Companies are required to be able to utilize their resources effectively and efficiently so that the company can have a competitive advantage (Mukaromah et al., 2022). Every organization is expected to develop a marketing

\* Corresponding author.

E-mail address [tita.fk@ub.ac.id](mailto:tita.fk@ub.ac.id) (T. Hariyanti)

strategy to survive in the face of competition, one of which is having a marketing strategy in the form of an appropriate marketing mix. This company's business strategy is expected to have an impact on financial and non-financial profits, survival in the industry, and to achieve the organization's long-term goals. Advances in technology, computers and telecommunications support the development of internet technology (Almana & Mirza, 2013). The internet provides benefits for business people so that they no longer experience difficulties in obtaining any information, to support their business activities, even now they tend to be able to obtain various kinds of information, so information must be filtered to get the right and relevant information (Alrwashdeh et al., 2019; Bahi et al., 2020). This method is effective in reaching consumers in very large numbers and can reach global consumers in a short time and with not too large funds. The use of internet marketing is currently considered important to implement in company marketing activities because it can reach a wider customer target compared to traditional media and is more cost-effective in marketing.

This is inversely proportional to the conditions of marketing carried out online. Before consumers purchase a product, they will certainly look for some information. One way is through word of mouth (WOM), which is an interesting strategy because this strategy combines low financing and fast interpersonal communication, especially through technology, such as the internet and social media. WOM which is spread through social media and communication applications has recently been known as electronic WOM (e-WOM). e-WOM is an important variable in marketing a product because it can contain comments or responses from other consumers who have made a purchase (Asnawati et al., 2022). Therefore, e-WOM can help consumers make purchasing decisions. Digital marketing and promotional activities using e-WOM through social media and internet technology can be one of the factors in increasing and maintaining brand awareness, where consumers are more aware and remember the brand of a product produced by the company, which in the end makes consumers loyal to the brand and product. Regarding online store awareness, the existence of awareness is very important in any business, including in marketing products and services marketed through digital marketing since it invites consumers to buy. Brand awareness in an online store describes the level of consumer recognition of a product with a brand. Consumers will tend to buy products from an online store that they already know well compared to products whose brands are newly known. The higher the level of a brand and the more value it can provide, the more likely it is that consumers will know or remember the brand, which will influence purchasing decisions (Purwanto & Praditya, 2023). Purchasing decisions made by consumers can be caused by brand awareness in an online store owned by consumers.

According to Asnawati et al. (2022), the entire marketing communication model influences the company, marketing communication that has the highest influence on purchasing decisions is internet marketing, brand awareness, and word of mouth communication, because internet marketing can provide messages or information to consumers and potential consumers about a product, brand awareness can make consumers think about using or buying a product, and WOM can provide an understanding from consumers to potential consumers regarding the experiences they have had about the consumer about a product or brand. Internet marketing is a company's effort to market products and services and build customer relationships via the internet. Internet marketing requires mastering the creative and technical aspects of the internet together, including design, development, advertising, and sales. Research conducted by Boonsiritomachai and Sud-On (2020) concluded that internet marketing has a positive and significant effect on purchasing decisions. Liao et al. (2012) concluded that with an advertising program using the internet, marketers can increase sales volume because marketing programs via the internet can influence purchasing decisions. This research aims to investigate the role of internet marketing variables on purchasing decisions in online stores, investigate the role of word-of-mouth variables on purchasing decisions in online stores and investigate the role of brand awareness variables on purchasing decisions in online stores.

## **2. Literature Review and Hypothesis Development**

### *2.1 Purchase decision*

The purchasing decision is one of the stages in the purchasing decision process before post-purchasing behavior. In entering the purchasing decision stage, consumers have previously been faced with several alternatives, so at this stage consumers will take action to decide to buy a product based on the choices that have been determined. According to Elseidi and El-Baz (2016), purchasing decisions are part of consumer behavior, consumer behavior is about how individuals, groups and organizations choose, buy and use goods, services, ideas or experiences to satisfy their needs and desires. A purchasing decision is a buyer's decision which is also influenced by his or her personality characteristics, including age, occupation, and economic situation. Consumer behavior will determine the decision-making process in making purchases (Lim, 2015). Purchasing decisions are consumer decisions that are influenced by financial economics, technology, politics, culture, products, prices, locations, promotions, physical evidence, people and processes. So, it forms an attitude in consumers to process all information and draw conclusions in the form of responses that emerge for the product to be purchased. Based on these definitions, it can be concluded that purchasing decisions are how consumers decide to buy or use an item/service by recognizing and processing it before making a purchasing decision. According to Purnamawati et al. (2022), every consumer or customer must identify their needs according to what they want, then look for information about the product and consider and determine which product they will decide to buy or use. Purchasing decisions are an integration process used to combine knowledge to evaluate two or more alternative behaviors and choose one of them. Consumer decisions are a problem-solving approach to human activities in purchasing goods or services to fulfil their wants and needs (Wallace et al., 2009; Rosário & Loureiro, 2021).

## 2.2 Internet Marketing

Internet marketing tends to refer to the perspective of how the internet can be used together with traditional media to obtain and provide services to customers in two ways (Juwaini et al., 2022). First, increasing efficiency in traditional marketing functions, second, marketing technology has changed marketing strategies a lot. An alternative term is e-marketing which can be considered to have a broader scope as it refers to the use of technology to achieve marketing objectives from an external and internal perspective. One aspect of internet marketing that is being widely discussed by people and is starting to be used by many companies to carry out integrated marketing communications activities today is a connector in new wave marketing in the social networking site *X* (formerly named Twitter) (Sulthana & Vasantha, 2019). Social media is a website owned to offer a social network in the form of a microblog, allowing its users to send and read messages. Internet marketing is a company's effort to market products and services and build customer relationships via the internet. Internet marketing requires mastering the creative and technical aspects of the internet together, including design, development, advertising and sales. According to Raouf and Esmaeel (2022), the Internet significantly reduces production costs. The internet network is a marketing channel used by advertisers, marketers and the public to find the best combination of marketing mix that suit customer needs. Research results prove that internet marketing and social networking media have a positive and significant influence on the decision-making process (Ruwaida et al., 2022).

## 2.3 Word of Mouth (WOM)

WOM does not require very large costs but can achieve enormous effectiveness (Selvi & Thomson, 2016). Supported by the habits of Indonesian people who like to socialize and tell each other about things they like and experience. There are five Ts that must be considered in pursuing effective and profitable WOM, namely Talker, Topics, Tools, Taking Part, and Tracking (Sudirjo et al., 2023). WOM is usually accepted more quickly by customers because those who convey it are those they can trust, such as experts, friends, family and mass media publications. The word-of-mouth strategy used by the companies aims to make consumers share the positive values of our company with other consumers. WOM is a communication process in the form of providing recommendations both individually and in groups regarding a product or service to provide personal information. WOM makes consumers curious when there are lots of conversations and even recommendations about something new. According to Siddiqui et al. (2021), WOM is informal communication aimed at other customers, the content of word of mouth can be information about the attributes of various products and services about use or the manufacturer. Own experience with products and services is considered the main stimulus that forms word of mouth. The spread of word of mouth is an important source of information for respondents to decide about purchasing products or services. Consumers try to get good information from the right sources to minimize information search costs and maximize the benefits of their consumption. Consumers have also learned that the quality of information for a particular product/service depends on the source of that information (Sharifpour et al., 2016). Negative words from word of mouth have undesirable effects, but positive words from word of mouth can create a magical impression or image of the product/service.) Word of mouth is related to the process of transferring information from one person to another through oral communication (Raouf & Esmaeel, 2022). The effect of word of mouth has a big meaning in influencing consumer purchasing decisions. Word of mouth has a significant positive effect on consumer purchasing decisions. Word of mouth has a significant influence in influencing someone to the point where they decide to make a purchase.

## 2.4 Brand Awareness

The ability of a potential buyer to recognize or recall a brand that is part of a particular product category. Brand awareness arises from a feeling of familiarity with the brand (Fahmi et al., 2022). The feeling of familiarity with this brand will give consumers a sense of confidence when they use the product. Then this feeling of trust will lead to a feeling that the risks faced by customers are reduced, which will ultimately lead customers to consider and choose the brand in question. The implementation of advertising programs is expected to have an impact on consumers, but this high awareness must be followed by consumer action. Brand awareness is the consumer's ability to identify a brand in different conditions, which can be done by brand recognition and recall of a particular brand (Liao et al., 2012). Brand Awareness is the ability of a potential consumer to recognize or recall that a brand is part of a particular product category. Brand awareness has an important effect on consumer decision-making by influencing the brands that are taken into consideration, and the influence of the brands selected from consideration. During the decision-making process, consumers choose products and brands that they are aware of or remember (Boonsiritomachai & Sud-On, 2020). This is an important consideration because a brand that is not part of the consideration will not be selected. In other words, brands that have a high top of mind have the highest probability of being chosen by consumers.

## 3. Hypothesis Development

### 3.1 The relationship of Internet Marketing on purchasing decisions

Nowadays, more and more online store consumers are using the internet to search for information about a product in an online store. Some studies show the potential impact of using internet marketing on the consumer decision-making process. Juwaini et al. (2022) examined internet marketing influencing product choice. According to Raouf and Esmaeel (2022), internet

marketing will become a very important reference for consumers in determining their purchasing decision making process. Based on previous studies, the following hypothesis was created:

**H<sub>1</sub>:** *Internet Marketing has a positive and significant effect on purchasing decisions.*

### 3.2 *The relationship of Electronic Word of Mouth on purchasing decisions*

Previous research by Sudirjo et al. (2023) shows that e-WOM messages are an important means by which consumers can obtain information about the quality of products or services. In addition, this kind of message can effectively reduce the risks and uncertainties that consumers are aware of when purchasing products or services, so that their purchase intentions and decision making can be better influenced. The research results of Siddiqui et al. (2021) show that online communication significantly influences the purchasing behavior of other consumers. The study of Sharifpour et al. (2016) explains the fact that e-WOM has become a permanent element by making a major contribution to brand image and online consumer purchasing decisions. Based on previous studies, the following hypothesis was created:

**H<sub>2</sub>:** *Electronic Word of Mouth has a positive and significant effect on purchasing decisions.*

### 3.3 *The relationship of Brand Awareness on purchasing decisions*

Brand Awareness can make consumers think about using or buying it. One form of brand awareness is a brand that is known to be reliable and whose quality can be accounted for (Widjaya, 2022). According to Asnawati et al. (2022), brand awareness plays an important role and makes a positive contribution to consumer decision-making. The findings further suggest that brands tend to represent certain quality perceptions. Brand awareness has a significant influence on purchasing decisions (Yaman, 2018). Research conducted by Sulthana and Vasantha (2019) concluded that the influence of brand awareness has a positive impact on purchasing decisions. When a person's level of brand awareness is high for a product brand, it will further increase the impression that remains in the minds of consumers and increase a person's confidence in the choice of a product brand. Selvi and Thomson (2016) concluded that brand awareness plays an important role and makes a positive contribution to consumer decision-making. The findings further suggest that brands tend to represent certain quality perceptions (Haudi et al., 2022). Research conducted by Oscarius et al. (2021) concluded that brand awareness plays an important role in consumer purchasing decisions regarding which brand to use. Based on the empirical study above, the research hypothesis is prepared as follows:

**H<sub>3</sub>:** *Brand Awareness has a positive and significant effect on purchasing decisions.*

## 4. Method

To achieve the study objectives, a self-administered survey questionnaire was developed based on the findings of the literature review. The questionnaire was pre-tested and revised. The survey consisted of four parts covering the following issues:

- 1) Internet Marketing
- 2) Word of Mouth Communication
- 3) Brand Awareness
- 4) Purchasing Decisions.

The research design used is an associative method since these variables are expected to have a relationship with one another. The respondent sampling technique used in this research is a non-probability sampling technique. The non-probability sampling technique in this research uses a purposive sampling technique, namely samples taken based on certain considerations. The responses to this research were from 468 online store consumers. The data collection method used in this research was a questionnaire giving a written list of questions to respondents. Measurements of "Internet Marketing", "Word of Mouth Communication", "Brand Awareness" and "Purchasing Decisions" were carried out using a seven-point Likert scale, ranging from strongly agree (1) to strongly disagree (7). The advantage of using an interval scale is that it permits the researchers to use a variety of statistical techniques that can be applied to nominal and ordinal scale data in addition to the arithmetic mean, standard deviation, product-moment correlations, and other statistics commonly used in marketing research. In this research, the data was analyzed using the Partial Least Square (PLS) method with SmartPLS version 3.0 software. The stages of research data analysis are outer model testing, namely unified validity and reliability, inner model testing and hypothesis testing.

### 4.1 *Outer Model Measurement*

The validity test is used to assess whether a questionnaire is valid or not. The validity of an instrument is how far the instrument measures what (object) a questionnaire wants to measure. Validity testing is applied to all question items for each variable. Several stages of testing will be carried out, namely through convergent validity, average variance extracted (AVE), and discriminant validity tests.

### 4.2 *Inner Structural Model*

Inner models (inner relations, structural models and substantive theory) describe the relationship between latent variables based on substantive theory. The structural model was evaluated using R-square for the dependent variable, t-tests and the significance of the structural path parameter coefficients. In assessing the model with PLS, start by looking at the R-square for each dependent latent variable.

### 4.3 Hypothesis testing

Hypothesis testing can be seen from the t-statistic value and probability value. To test the hypothesis, namely by using statistical values, for  $\alpha$  (5%) the t-statistic value used is 1.96. So, the criteria for accepting/rejecting the hypothesis are  $H_a$  accepted and  $H_o$  rejected when the t-statistic  $> 1.96$ . To reject/accept a hypothesis using probability,  $H_a$  is accepted if the p-value  $< 0.05$ . Fig. 1 shows the structure of the proposed study.

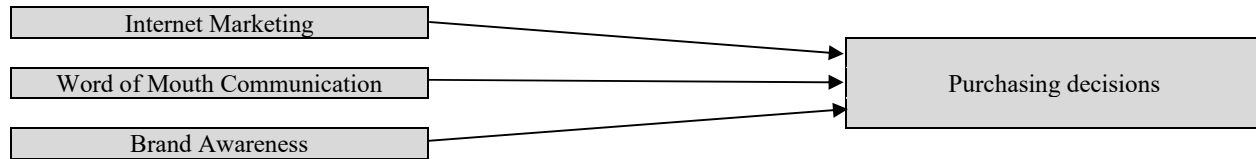

Fig. 1. Research Model

## 5. Results and Discussion

### 5.1 Respondents profile

The responses to this research were from 468 online store consumers. The data collection method used in this research was a questionnaire giving a written list of questions to respondents. Based on the results of the questionnaire, the following respondent profile data was obtained, Descriptive statistics are displayed in Table 1.

**Table 1**  
Respondents profile

Characteristics	Total	%	
Age	< 20 Years	23	4.91%
	20 - 30 Years	123	26.28%
	31 - 40 Years	234	50.00%
	> 40 Years	88	18.80%
Gender	Male	324	69.23%
	Female	144	30.77%
Online shop Customers	< 1 Years	56	11.97%
	2 - 5 Years	134	28.63%
	6 - 10 Years	167	35.68%
	> 10 Years	111	23.72%
Education Level	High School	54	11.54%
	Diploma	234	50.00%
	Post Graduate	143	30.56%
	Master	37	7.91%

Most respondents have an age of 31 - 40 years, namely 50.00%. For gender, most respondents are male, namely 69.23%. Most respondents have used online shops for 6 - 10 years, namely 35.68% and the highest education level of respondents is Diploma, namely 50.00%.

### 5.2 Validity test

The proposed structural model was estimated by structural equation modeling (SEM), which included a test of the overall model fit and individual tests of the significance of the relationships among the variables. In Fig. 2 and Table 2, the outer loading value for each statement item for all variables shows that some are more than 0.5, and statement items that have a loading value  $> 0.5$  meet convergent validity so they can be used for further analysis processes.

**Table 2**  
Loading Factors, Cronbach Alpha, CR and AVE

Variables	Items	Factor Loadings	Cronbach's Alpha	rho A	Composite Reliability	Average Variance Extracted
Internet Marketing	IM1	0.903	0.813	0.887	0.854	0.713
	IM2	0.907				
	IM3	0.913				
Word of Mouth	WO	0.939	0.832	0.864	0.856	0.743
	WO	0.926				
	WO	0.925				
Brand Awareness	BA1	0.920	0.843	0.872	0.843	0.764
	BA2	0.906				
	BA3	0.862				
Purchasing decision	PD1	0.925	0.776	0.832	0.16	0.726
	PD2	0.930				
	PD3	0.943				

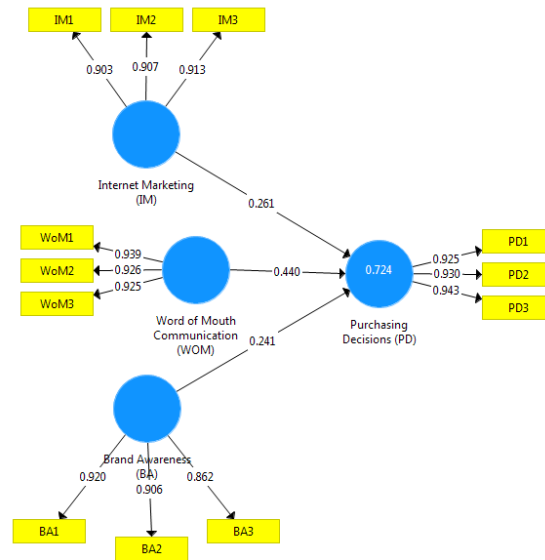

**Fig. 2.** Validity Testing

Based on Table 1, it is known that all constructs show an AVE value of more than 0.50. This value meets the requirements by the specified minimum AVE value limit, namely 0.50. Therefore, it is concluded that all constructs meet the validity requirements. After knowing the square root value of AVE for each construct, the next stage is to compare the square root of AVE with the correlation between constructs in the model. Based on the data presented in Table 1 above, all composite reliability values of the research variables are  $> 0.7$ . These results indicate that all variables have met composite reliability, so it can be concluded that all variables do not have a high level of reliability.

### 5.3 Discriminant validity

The discriminant validity test is used to check the discriminant between measurement scales in research. The Heterotrait-Monotrait (HTMT) discriminant validity limit value cannot be greater than 0.90.

**Table 3**  
Discriminant Validity

	Internet Marketing	Word of Mouth	Brand Awareness	Purchasing Decision
Internet Marketing				
Word of Mouth	0.832			
Brand Awareness	0.812	0.713		
Purchasing Decision	0.713	0.645	0.712	

### 5.4 Hypothesis testing

Based on the analysis of the data that has been processed, the results can be used to answer the hypothesis in this research. Hypothesis testing in this research was carried out by looking at the t-statistic values and probability values. The research hypothesis can be declared accepted if the t statistic is  $> 1.96$  and the probability value is  $< 0.05$ . The following are the output results from SmartPLS which are shown in Table 3 and Fig. 2.

**Table 4**  
Hypothesis Testing

Correlation	Original Sample	t Statistics	P Values	Result
Internet Marketing $\rightarrow$ Purchasing Decision	0.261	3.865	0.000	Significant
Word of Mouth $\rightarrow$ Purchasing Decision	0.440	5.501	0.000	Significant
Brand Awareness $\rightarrow$ Purchasing Decision	0.241	2.502	0.000	Significant

The statistical results, summarized in Table 4, have generated three major findings:

- (1) Internet Marketing has a positive and significant effect on purchasing decisions.
- (2) Word of Mouth Communication has a positive and significant effect on purchasing decisions.
- (3) Brand Awareness has a positive and significant effect on purchasing decisions.

Hypothesis testing can be seen from the t-statistic value and probability value. To test the hypothesis, namely by using statistical values, for  $\alpha$  (5%) the t-statistic value used is 1.96. So the criteria for accepting/rejecting the hypothesis are  $H_a$  accepted and  $H_0$  rejected when the t-statistic  $> 1.96$ . To reject/accept a hypothesis using probability,  $H_a$  is accepted if the p-value  $< 0.05$ .

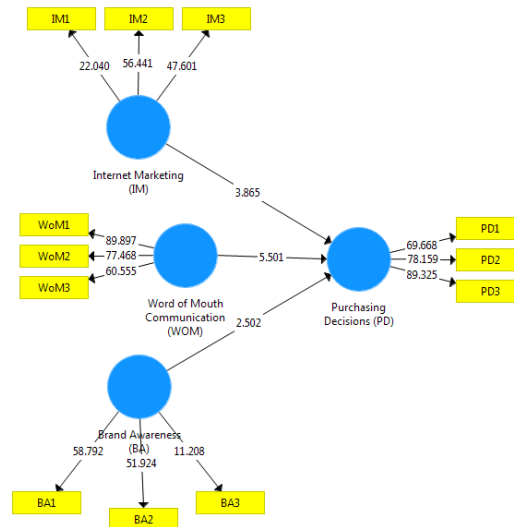

Fig. 3. Hypothesis Testing

#### 5.4.1 The Relationship between internet marketing and purchasing decisions

The results of hypothesis testing show that the internet marketing variable has a positive and significant effect on purchasing decisions. After testing, the research results show that significance level value of  $0.000 < 0.05$ , thus it can be interpreted that internet marketing has a positive and significant effect on purchasing decisions, so the hypothesis in this research can be accepted. The results of this research are supported by the results of previous research conducted by Mulyandi and Tjandra (2022) concluding that with advertising programs using the Internet, marketers can increase sales volume because marketing programs via the Internet can influence purchasing decisions. Research conducted by Praditya and Purwanto (2024) obtained the results that internet marketing has a significant influence on purchasing decisions, where the internet marketing strategy aims to make consumers feel comfortable and create interaction between consumers, customers who are satisfied with the company are certainly easier to decide to buy. Apart from that, research conducted by Mulyadi et al. (2023) stated that the use of Internet marketing provides an opportunity for companies to reach wider and more cost-effective customer targets. This research shows that Internet marketing has a significant influence on purchasing decisions. These results mean that better internet marketing will improve consumer purchasing decisions. This is by the results of research by Rosário and Loureiro (2021) which states that there is a positive influence between internet marketing and purchasing decisions. Internet marketing is a company's effort to market products and services and build customer relationships via the Internet (Martha et al., 2023). Internet marketing requires mastering the creative and technical aspects of the Internet together, including design, development, advertising and sales. Research conducted by Elseidi and El-Baz (2016) concluded that internet marketing has a positive and significant effect on purchasing decisions. Lim (2015) concluded that with the existence of advertising programs using the internet, marketers can increase sales volume because marketing programs via the internet can influence purchasing decisions.

#### 5.4.2 The relationship between word-of-mouth communication and purchasing decisions

The results of hypothesis testing show that the word-of-mouth communication variable has a positive and significant effect on purchasing decisions. After testing, the research results show that significance level value of  $0.000 < 0.05$ , thus it can be interpreted that word-of-mouth communication has a positive and significant effect on purchasing decisions, so the hypothesis in this research can be accepted. The results of this research are supported by the results of previous research conducted by Sudirjo et al. (2023) which concluded that the word-of-mouth variable has a significant influence on purchasing decisions. Consumers will carry out word-of-mouth activities and tell their experiences after consuming the product to other people such as friends, relatives, and friends. If the experience gained is positive, then the word of mouth is also positive and vice versa. This research is also supported by the results of research conducted by Sudirjo et al. (2023) concluding that the word-of-mouth variable which consists of two indicators, namely reference group and opinion leader, influences purchasing decisions. When an individual's interest in buying arises and his belief in a product strengthens, then a purchasing decision can be made. If the experience obtained is positive, then the word of mouth that is carried out is also positive and vice versa. The results of testing the second hypothesis show that word of mouth has a significant effect on brand awareness. Siddiqui et al. (2021) state

that every human being has their brain intelligence. The process of recalling or brand recall is also influenced by each human's brain intelligence system which is sometimes easier to remember images than writing and numbers (Sharifpour et al., 2016). This causes word of mouth that occurs on  $X$ , which tends to emphasize writing, to become less memorable in the minds of followers who read the word of mouth.

#### *5.4.3 The relationship between brand awareness and purchasing decisions*

The results of hypothesis testing show that the brand awareness variable has a positive and significant effect on purchasing decisions. After testing, the research results show that significance level value of  $0.000 < 0.05$ , thus it can be interpreted that brand awareness has a positive and significant effect on purchasing decisions, so the hypothesis in this research can be accepted. The results of this research are supported by the results of previous research conducted by Sudirjo et al. (2023) which states that the role of brand awareness in purchasing decisions depends on the awareness of a brand in the minds of consumers. Consumers tend to buy and choose products with known brands because consumers will feel safer and avoid various risks that might occur. Research conducted by Raouf and Esmaeel (2022) concluded that the influence of brand awareness has a positive impact on purchasing decisions, when a person's level of brand awareness is high for a product brand, it will further increase the impression that remains in the minds of consumers and increase a person's confidence in the choice of a product brand. The results of this research are also supported by research conducted by Purwanto et al. (2023) who obtained the results that brand awareness has a significant positive influence on purchasing decisions, consumers will tend to buy brands that are already known because they feel safe with something that is already known. In other words, a brand that is known to have reliable and accountable quality. Research conducted by Sulthana and Vasantha (2019) concluded that the influence of brand awareness has a positive impact on purchasing decisions. When a person's level of brand awareness is high for a product brand, it will further increase the impression that remains in the minds of consumers and increase a person's confidence in the choice of a product brand. Selvi and Thomson (2016) brand awareness plays an important role and makes a positive contribution to consumer decision-making. The findings further suggest that brands tend to represent certain quality perceptions. Research conducted by Oscarius et al. (2021) brand awareness plays an important role in consumer purchasing decisions regarding which brand to use. Consumers will tend to buy brands that are already known because they feel safe with something that is already known.

#### *5.5 Practical and Managerial implications*

Our empirical study has shown that Internet Marketing has a positive and significant effect on purchasing decisions and indirectly leads to purchasing intentions, especially in online stores. In addition, we have shown that WOM has a positive and significant effect on purchasing decisions. This has been proven by many studies before ours, but not in online stores. Our results have several important implications. The finding that Word of Mouth Communication can generate purchase intentions is very important for online stores. Through mobile internet which is increasing day by day. Based on the results of data analysis, provide managerial implications as follows: online stores should evaluate the Internet marketing strategy used by the company by looking for information about what is currently trending among the public and forming a special team to carry out Internet marketing strategies to make them more attractive and creative and provide more complete information regarding products are marketed so that they attract consumers to make purchasing decisions. The company is expected to continue to innovate and maintain product quality as well as introduce products with attractive promotions so that the product brand will make an impression on consumers, this will make consumers trust and be confident in buying online store products. Online stores are expected to maintain product quality and provide more diverse product innovations so that consumers get more of the benefits they need from online store products so that consumers will respond positively to online store products. Internet marketing regarding products continues to be developed considering the world is turning towards the digital era and the era of social networking, but the development of Internet marketing should be balanced with developments in marketing through other media such as newspapers or television so that more potential consumers see it so that the effectiveness of advertising and awareness of a brand will increase.

## **6. Conclusions and recommendations**

Based on the results of data analysis, it is concluded that internet marketing has a positive and significant effect on purchasing decisions, Word of Mouth Communication has a positive and significant effect on purchasing decisions and brand awareness has a positive and significant effect on purchasing decisions.

Based on the results of research, analysis and interpretation of data as well as the conclusions that have been presented, the advice that can be given is that respondents' assessment of internet marketing used by online stores can generally be said to be good, however companies should evaluate the internet marketing strategy used by the company by looking for information about what is currently trending among the public and forming a special team to carry out internet marketing strategies to make them more attractive and creative and provide more complete information about the products being marketed to attract consumers to make purchasing decisions. Respondents' assessment of the brand awareness used by online store companies can generally be said to be good. The company is expected to continue to innovate and maintain product quality as well as introduce products with attractive promotions so that the product brand will make an impression and stick in the minds of consumers, this will make consumers trust and be confident in buying online store products. Respondents' assessment of



word-of-mouth communication can generally be said to be good, however, companies are expected to maintain the quality of their products and provide more diverse product innovations so that consumers get more of the benefits they need from online store products so that consumers will give positive responses to online products.

Internet marketing regarding products continues to be developed considering that the world is moving towards the digital era and the era of social networks, but the development of Internet marketing should be balanced with the development of marketing through other media such as newspapers or television so that more potential consumers see it so that advertising effectiveness and brand awareness will increase. It is hoped that future researchers will be able to research other variables outside of the variables that have been studied to obtain more varied results that can influence purchasing decisions. It would be better for future research to further expand the research object, and look for a wider population scope, as well as a larger sample so that it can provide a more specific picture. Companies should add admins to each social network and employ admins on a shift system so that it becomes effective internet marketing. This needs to be done because internet users who access social networks can be active at any time and can be an opportunity for marketers to market to different people at any time.

## References

- Aileen, E., Gaberamos, O., Bernarto, I., & Pasaribu, L. H. (2021). The Effect Of Social Media Marketing, Word Of Mouth, And Effectiveness Of Advertising On Brand Awareness And Purchase Intention On Grab Application Users Domicile Of Tangerang. *Enrichment: Journal of Management*, 12(1), 426-441.
- Almana, A. M., & Mirza, A. A. (2013). The impact of electronic word of mouth on consumers' purchasing decisions. *International Journal of Computer Applications*, 82(9), 23-31.
- Alrwashdeh, M., Emeagwali, O., & Aljuhmani, H. (2019). The effect of electronic word of mouth communication on purchase intention and brand image: An applicant smartphone brands in North Cyprus. *Management Science Letters*, 9(4), 505-518.
- Asnawati, A., Nadir, M., Wardhani, W., & Setini, M. (2022). The effects of perceived ease of use, electronic word of mouth and content marketing on purchase decision. *International Journal of Data and Network Science*, 6(1), 81-90.
- Bahi, H. A., Pratikto, H., & Dhewi, T. S. (2020). The impact of e-wom and advertising on purchase decision is. se. sa syar'i clothes with brand awareness as an intervening variables (a study on si. se. sa fashion consumers). *International Journal of Business, Economics and Law*, 23(1), 255-261.
- Boonsiritomachai, W., & Sud-On, P. (2020). Increasing purchase intention and word-of-mouth through hotel brand awareness. *Tourism and hospitality management*, 26(2), 265-289.
- Liao, S. H., Wu, C. C., Widowati, R., & Chen, M. Y. (2012). Relationships between brand awareness and online word-of-mouth: An example of online gaming community. *International Journal of Web Based Communities*, 8(2), 177-195.
- Elseidi, R. I., & El-Baz, D. (2016). Electronic word of mouth effects on consumers' brand attitudes, brand image and purchase intention: an empirical study in Egypt. *The Business & Management Review*, 7(5), 268.
- Haudi, H., Rahadjeng, E., Santamoko, R., Putra, R., Purwoko, D., Nurjannah, D. (2022). The role of e-marketing and e-CRM on e-loyalty of Indonesian companies during Covid pandemic and digital era. *Uncertain Supply Chain Management*, 10(1), 217-224.
- Juwaini, A., Chidir, G., Novitasari, D., Iskandar, J., Hutagalung, D., Pramono, T. (2022). The role of customer e-trust, customer e-service quality and customer e-satisfaction on customer e-loyalty. *International journal of data and network science*, 6(2), 477-486.
- Lim, W. M. (2015). The influence of internet advertising and electronic word of mouth on consumer perceptions and intention: Some evidence from online group buying. *Journal of Computer Information Systems*, 55(4), 81-89.
- Martha, L., Primadewi, A., Priwirjanto, E., Fatmawati, E., Nahdiana, N., Yustina, I., ... & Hidayati, L. (2023). The effects of digital marketing, word of mouth, and service quality on the purchase decisions: An empirical study of food SMEs products. *International Journal of Data and Network Science*, 7(3), 1117-1124.
- Mukaromah, H., Muhajir, M., Fathudin, F., Purwanti, K., Ansori, Y., Fahlevi, M., (2022). The role of buzz and viral marketing strategic on purchase intention and supply chain performance. *Uncertain Supply Chain Management*, 10(2), 637-644.
- Mulyadi, M., Hariyadi, H., Hakim, L., Achmad, M., Syafri, W., Purwoko, D., ... & Muksin, M. (2023). The role of digital marketing, word of mouth (WoM) and service quality on purchasing decisions of online shop products. *International Journal of Data and Network Science*, 7(3), 1405-1412.
- Mulyandi, M. R., & Tjandra, R. H. (2022). The Influence of Product Quality and Brand Image on repurchase Intention of Halal Cosmetic Products in e-Commerce. *Journal of Industrial Engineering & Management Research*, 4(1), 41- 52. <https://doi.org/10.7777/jiemar.v4i1.438>
- Oscarius, A. P., Sulistiyani, S., Pudjowati, J., Kartikawati, T. S., Kurniasih, N. (2021). The role of social media marketing, entertainment, customization, trendiness, interaction and word-of-mouth on purchase intention: An empirical study from Indonesian smartphone consumer. *International Journal of Data and Network Science*, 5(3), 231-238.
- Praditya, R. A., & Purwanto, A. (2024). The Role of Viral Marketing, Brand Image and Brand Awareness on Purchasing Decisions. *PROFESOR: Professional Education Studies and Operations Research*, 1(01), 11-15.
- Purnamawati, I. P. S., Putra, I. M. W., & Wahyuni, N. M. (2022). The Effect of Brand Image on Online Purchase Decision with Mediation Word of Mouth on Fashion Products in Denpasar-Bali Province. *Jurnal Ekonomi & Bisnis JAGADITHA*, 9(1), 90-98.
- Purwanto, A., & Praditya, R. A. (2024). The Role of Celebrity Endorsements, Electronic Word of Mouth, and Product Placement on Purchasing Decisions. *PROFESOR: Professional Education Studies and Operations Research*, 1(01), 6-10.

- Purwanto, A., Purba, J., Bernarto, I., & Sijabat, R. (2023). Investigating the role digital transformation and human resource management on the performance of the universities. *International Journal of Data and Network Science*, 7(4), 2013-2028.
- Rosário, J. F. D., & Loureiro, S. M. C. (2021). The effectiveness of e-word-of-mouth communication about smartphones purchase intention: digital influencer. *International Journal of Internet Marketing and Advertising*, 15(4), 429-449.
- Ruwaida, R., Sihombing, F., Kurniawati, S., & Sulaiman, A. (2023). The effect of Service Quality, Pricing, and Customer Satisfaction on Customer Loyalty Gojek Transportation at 3rd Hamlet Paseban District, Central Jakarta. *Journal of Industrial Engineering & Management Research*, 4(3), 1-7.
- Siddiqui, M. S., Siddiqui, U. A., Khan, M. A., Alkandi, I. G., Saxena, A. K., & Siddiqui, J. H. (2021). Creating electronic word of mouth credibility through social networking sites and determining its impact on brand image and online purchase intentions in India. *Journal of Theoretical and Applied Electronic Commerce Research*, 16(4), 1008-1024.
- Sulthana, A. N., & Vasantha, S. (2019). Influence of electronic word of mouth eWOM on purchase intention. *International Journal of Scientific and Technology Research*, 8(10), 1-5.
- Raouf, R. A., & Esmael, R. I. (2022). The Effects of Positive Word of Mouth in Mediating Brand Equity and Purchase Decision: A Study of Iraqi Customers. *Webology*, 19(2).
- Sharifpour, Y., Khan, M. N. A. A., Alizadeh, M., Akhgarzadeh, M. R., & Mahmodi, E. (2016). The influence of electronic word-of-mouth on consumers' purchase intentions and brand awareness in Iranian telecommunication industry. *International Journal of Supply Chain Management*, 5(3), 133-141.
- Selvi, B. M., & Thomson, J. E. (2016). An exploratory study on the electronic word of mouth communication in promoting brands in the online platforms. *Intelligent Information Management*, 8(5), 115-141.
- Sudirjo, F., Astuti, A. K., Kowey, W. O., & Transistari, R. (2023). Analysis of The Influence of Electronic Word of Mouth, Brand Awareness and Digital Accessibility on Purchase Decision of Sayurbox Consumers. *Jurnal Informasi dan Teknologi*, 53-58.
- Wallace, D., Walker, J., Lopez, T., & Jones, M. (2009). Do word of mouth and advertising messages on social networks influence the purchasing behavior of college students?. *Journal of Applied Business Research (JABR)*, 25(1).
- Widjaya, R. (2022). The Relationship Modelling of Advertising, Electronic Word of Mouth and Brand Awareness on Fashion Product Purchasing Decision. *JBMP (Jurnal Bisnis, Manajemen dan Perbankan)*, 8(2), 168-192.
- Yaman, Z. (2018). The effect of word of mouth marketing on the purchase behavior via brand image and perceived quality. *Montenegrin Journal of Economics*, 14(2), 175-182.



© 2024 by the authors; licensee Growing Science, Canada. This is an open access article distributed under the terms and conditions of the Creative Commons Attribution (CC-BY) license (<http://creativecommons.org/licenses/by/4.0/>).